

Countertop Fryer W.FRSxx / W.FRTxx



Product Information:

- Mechanical thermostat temperature control
- Designed for 180°C frying
- Suitable for use with liquid oil only
- Over temperature safety cut-out as standard
- Stainless steel element covers
- Basket holder at rear for draining
- Removable splash guard
- Removable tilting element assembly
- Easily removable oil tank
- Snug fitting stainless steel tank cover
- Drip tray supplied complete with basket(s)
- Power on and indicator light

Specifications:

Model	W.FRS50	W.FRS80
Height	355mm	384mm
Width	285mm	285mm
Depth	483mm (619mm with basket)	483mm (619mm with basket)
Power	2.2kW 10A plug & lead fitted	3.2kW 15A plug & lead fitted
Capacity	5 Litre 8.5kg/hr (frozen 10mm chips)	8 Litre 11.5kg/hr (frozen 10mm chips)

Model	W.FRT50	W.FRT80
Height	355mm	384mm
Width	550mm	550mm
Depth	483mm (619mm with basket)	483mm (619mm with basket)
Power	2 x 2.2kW 2 x 10A plug & lead fitted *2 separate 10A circuits	2 x 3.2kW 2 x 15A plug & lead fitted *2 separate 15A circuits
Capacity	2 x 5 Litre 2 x 8.5kg/hr (frozen 10mm chips)	2 x 8 Litre 2 x 11.5kg/hr (frozen 10mm chips)

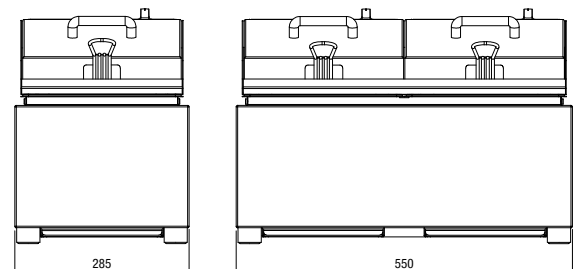
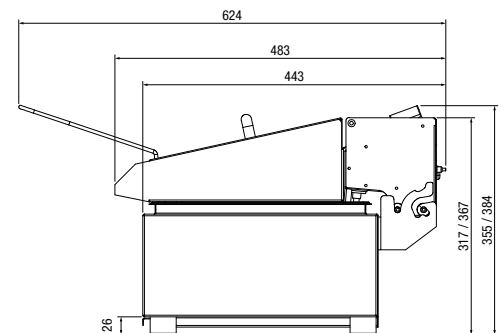

Due to continuous product research and development, the information contained herein is subject to change without notice.

Revision: C - 25/05/2022 - 01

www.stoddart.com.au

www.stoddart.co.nz