

ONLY FROM

nemco[®] | FOOD
EQUIPMENT

Easy Tomato Slicer™

Now anyone can get perfect, uniform tomato slices with remarkable speed!

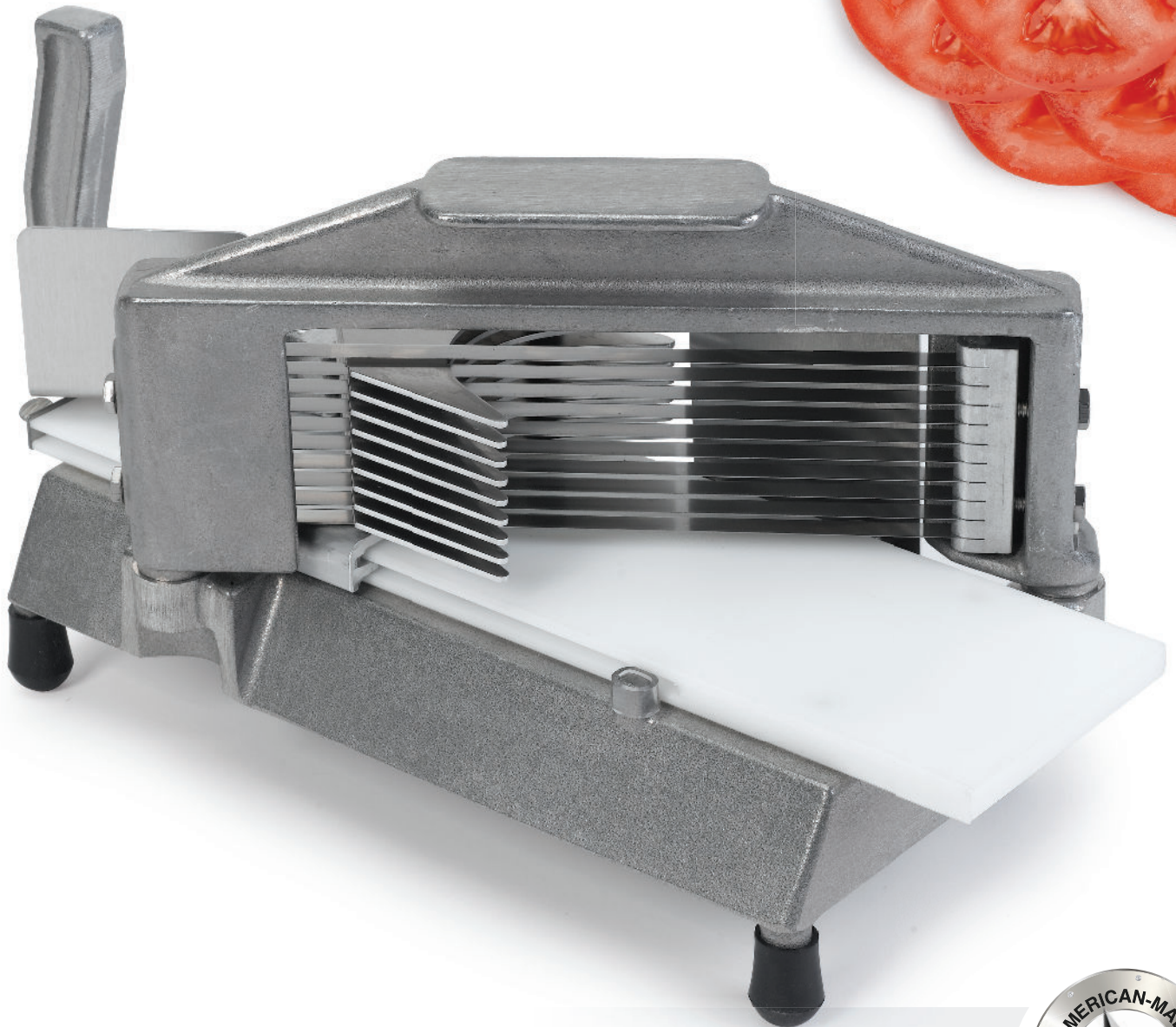

Buy once. Buy the original.
Always look for this mark of quality





The Slice Is Right... Every Time

One motion. That's all it takes. So, even your most inexperienced kitchen employee can yield precise uniform tomato slices at super speed.

Perfectly Efficient

Everything about the Easy Tomato Slicer is designed to maximize your food-prep margin. It works fast, demands very little space and gets the most out of every tomato.

- Saves labor—Place a tomato in front of the pusher, and slide it through the blade assembly for multiple uniform slices—all in less than three seconds.
- Saves food cost—Get the same slice thickness throughout, using the entire tomato, for consistent presentation and portion control.
- Saves space—We're talkin' a footprint as small as a shoebox on your counter.

Simply Easy to Use

Compact, portable and operator-friendly, the Easy Tomato Slicer is a model of productivity in anyone's hands.

- It's nicely weighted, with a low, sturdy center of gravity, yet it's not cumbersome to move. It quickly sets up and goes to work virtually anywhere on the counter and stores away again—no sweat.
- The ergonomic handle and smooth-glide track eliminate operator fatigue.
- Protective guards optimize safety.

Stubbornly Built to Last

Equal parts strength and finesse make it the perfect design for maximum ROI.

- Cast-aluminum and stainless-steel construction stands up to the brutality of a commercial kitchen and cleans up with ease.
- The blades are razor-sharp 301 stainless steel for lasting performance.
- A self-lubricating track material alleviates misalignment problems that can nick or break the blades.

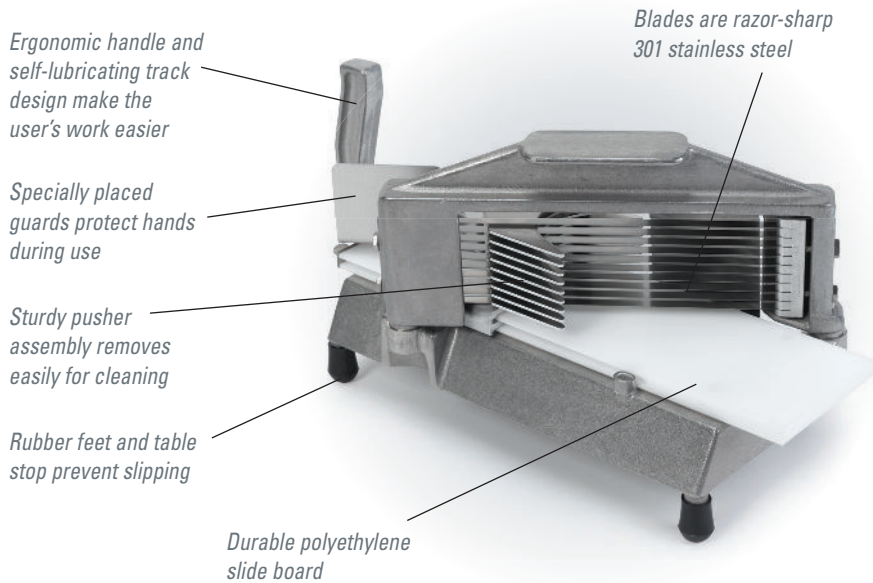

Suggested Uses

This is a must-have if you like to keep fresh tomatoes on hand for your burgers, sandwiches, salads, salad bars and condiment trays. It's great for slicing strawberries and mushrooms too.

General Specifications

Model	Description	Slice Diameter
55600-1	3/16" Slice	Up to 3 1/4"
55600-2	1/4" Slice	Up to 3 1/4"
55600-3	3/8" Slice	Up to 3 1/4"
55600-7	7/32" Slice	Up to 3 1/4"

Optional Accessories

466-1	3/16" Blade Assembly
466-2	1/4" Blade Assembly
466-3	3/8" Blade Assembly
466-7	7/32" Blade Assembly

Dimensions

Equipment (w x d x h)	7 1/4" x 15 1/4" x 8 1/4"
Shipping Carton (l x w x h)	16 1/2" x 8 1/2" x 9 1/2"
Equipment Weight	8 lbs
Shipping Weight	9 lbs

Replacement parts are available through Nemco's 24-hour Zip Program.

Nemco reserves the right to make design, specification or model changes without notice.



nemco® | FOOD EQUIPMENT

Physical Address: Corporate HQ
301 Meuse Argonne | Hicksville, OH 43526
800.782.6761 • 419.542.7751 • f: 419.542.6690

Mailing Address:

PO Box 305 | Hicksville, OH 43526

Nemco West Distribution Center/Test Kitchen
4300 E Magnolia Street | Phoenix, AZ 85034

NemcoFoodEquip.com



Printed 10/18. Printed in the U.S.A.