

Evox 25



Touch panel



Ultra-rapid vacuum



Easy to use

Excellent technology, compact design

Compact, ergonomic, versatile and equipped with vacuum sensor, Evox 25 represents a result of absolute excellence. Its surprisingly small dimensions, including a height of only 21 cm, make the Evox 25 the perfect vacuum packaging machine for use in any business or kitchen with small spaces.

Evox 25 is ideal for:



Small restaurant



Bar



Small gastronomy



Butcher shops

Packing methods



Sealing only



Vacuum



External vacuum

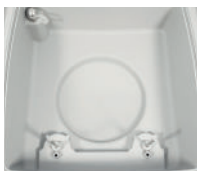

Ultra-resistant vacuum chamber

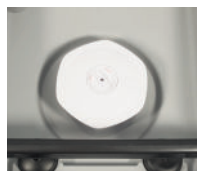

Containers base



Suction valve



Removable sealing bar without tools



Always perfect chamber cleaning

Technical data

- > Bodywork: stainless steel
- > Size: 444x477x210h mm
- > Chamber size: 303x293x110h mm
- > Chamber volume: 7,65 lt.
- > Weight: 22 kg
- > Power grid voltage: 240V 50/60Hz
- > Max power absorption: 240 W
- > Sealing bars: 260 mm
- > Vacuum pump: 4 mc/h
- > Final pressure: 2-4 mbar
- > Max bag size: 250x300 mm

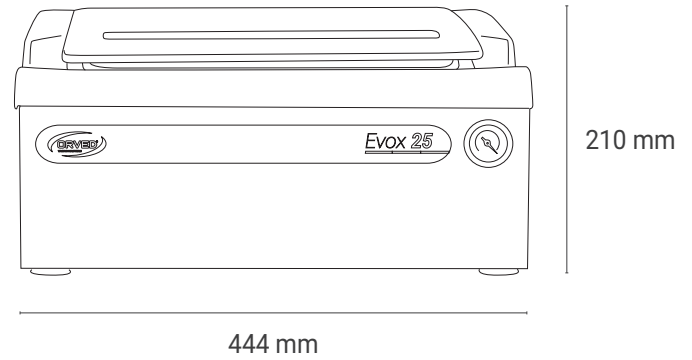

Standard equipment



Touch panel



Easy accessory included



Suction tube included



Vacuum sensor



H2out pump dehumidification program



Device to operate vacuum in container

Matching accessories



Smooth vacuum bags



Channelled vacuum bags



Cooking vacuum bags



Carriage



Conserbox containers



Easy for external vacuum

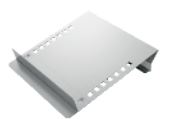

Inclined shelf for liquid products