

Multiple 315



Ultra resistant vacuum chamber



Electromechanical command panel



100% Made in Italy pump

Simplicity, comfort and reliability

"Manual planning in order to, once more, make the final user the only manager of any Vacuum process"

Multiple 315 incorporates all the features that distinguish Orved quality, such as the vacuum chamber, designed with particular attention to the hygienic aspect, found in the rounded corners that facilitate cleaning. Equipped with H2out pump dehumidification cycle, Multiple 315 can pack any type of food and the Easy accessory allow the creation of external vacuum with surprising rapidity.

Multiple 315 is ideal for:



Small restaurant



Bar



Small gastronomy

Packing methods



Sealing only



Vacuum

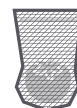

External vacuum

Technical data

- > Bodywork: stainless steel
- > Size: 435x420x325h mm
- > Chamber size: 330x335x100h mm
- > Weight: 32 kg
- > Power grid voltage: 240V 50/60Hz
- > Max power absorption: 450 W
- > Sealing bars: 315 mm
- > Vacuum pump: 8 mc/h
- > Max bag size: 300x350 mm

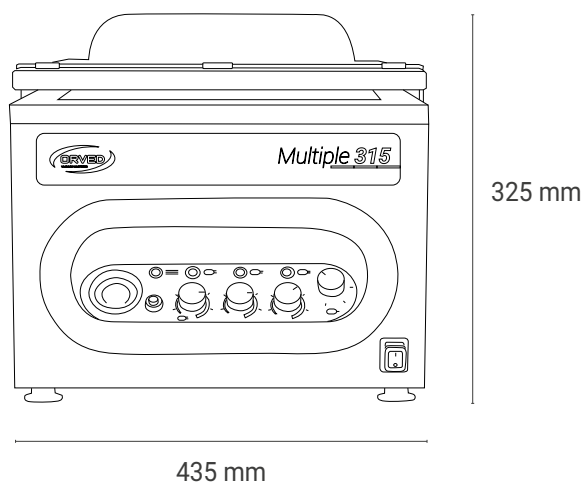

Standard equipment

 Easy accessory included

 H2out pump dehumidification program

 Nozzle for jars

Optional on request

 Set of vacuum bags Basic

Matching accessories



Smooth vacuum bags



Channelled vacuum bags



Cooking vacuum bags



Carriage



Conserbox containers



Easy for external vacuum



Inclined shelf for liquid products