



VFG1L 800 SERIES FRYER

Gas, 2 baskets



VFG1L standard features and benefits

- “V” pan fryer combines high energy efficiency, quick response and recovery and easy cleaning
- Stainless steel pan front and sides
- Large cool zone for long oil life
- Mechanical control with fenwal thermostat provides unrivalled accuracy of +/- 1 °C
- Highly accurate optimal cooking temperature range 150 – 190 °C
- Rapid heating response and electronic temperature control accuracy from a mechanical device which is easy to service
- Manual spark ignition
- Line-up nosing for a sleek appearance
- All components easily serviceable from the front

Standard accessories

- Two nickel plated wire mesh fry baskets
- Night lid
- Adjustable legs 140-170 mm

Optional accessories part codes

FRV00P31	Fish plate
C2	4” Rear castors set of 2
C4	4” Rear castors set of 4
Chain	Teether chain, for use with castors
Cover/joiner strips for multi-unit installations:	
FRV00P36	VFG1L joins to VFG1L
FRV00P44	VFG1L joins to VFGT or VFG24
FRV00P40	VFG1L joins to TGF1M or TGF24



Please note, due to ongoing product development and improvement, we reserve the right to change product design and specification at any time without notice.



1800 013 123 | +61 2 9604 7333
sales@middleby.com.au
middleby.com.au

VIC - TAS - 47 Stubbs Street, Kensington VIC 3031
QLD - U12, 210 Queensport Rd Nth, Murarrie QLD 4172
WA - U2, 9 Meares Way, Canning Vale WA 6155, 08 9456 0559

HEAD OFFICE
AND MANUFACTURING PLANT
211-217 Woodpark Road, Smithfield NSW 2164

v1_2022



VFG1L 800 SERIES FRYER

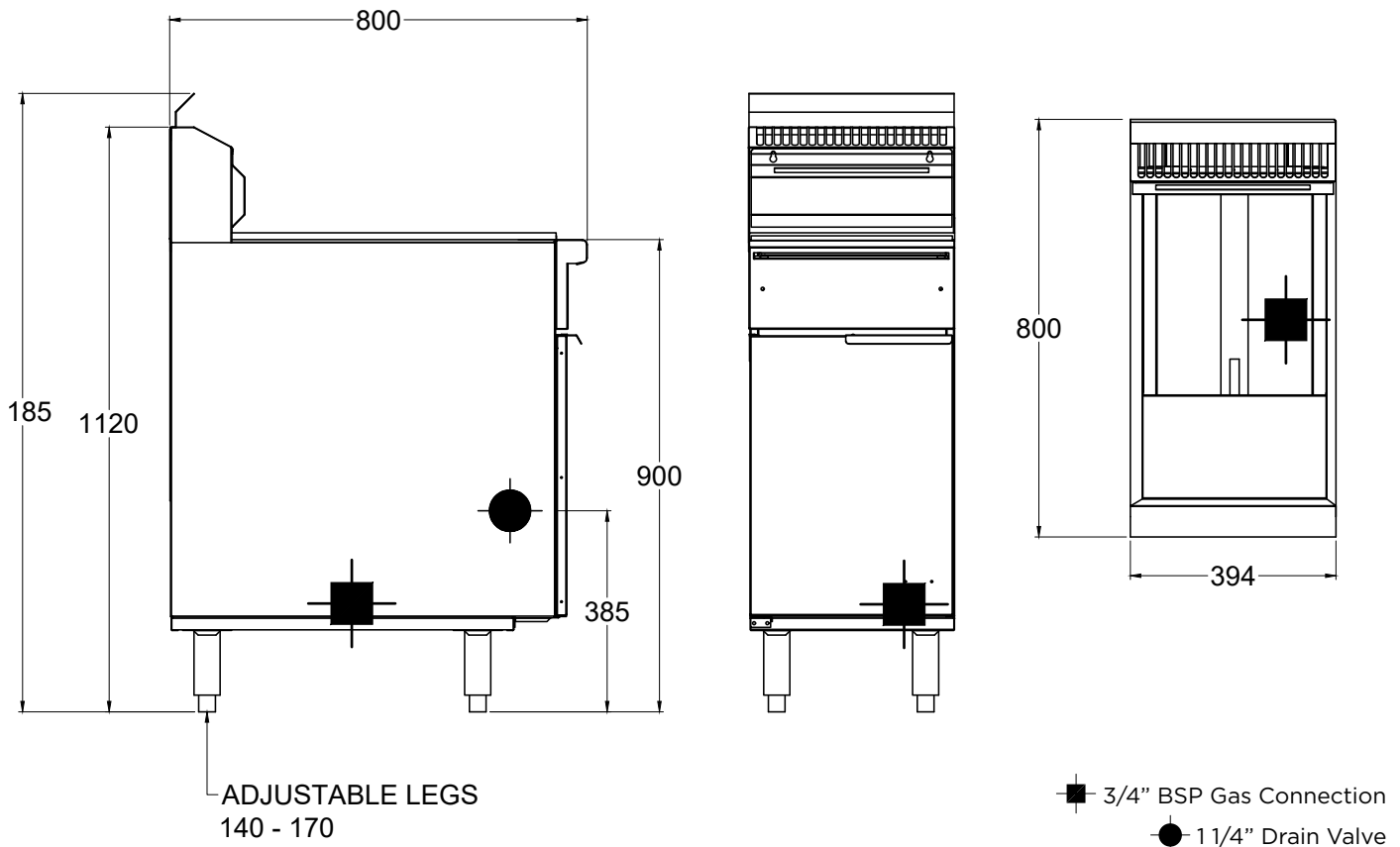

VFG1L SPECIFICATIONS

Dimensions (WxDxH)	395 x 800 x 1120 mm
Working height	900 mm (± 20 mm)
Pan size (WxDxH)	353 x 353 x 300 mm
Baskets	2
Capacity	20 L

Drain valve	1 1/4"
Production rate	29 kg/h
Gas connection	3/4" BSP
Rating NG/LPG	97 Mj / 95 Mj
Packed weight	70 kg
Packed dimensions	530 x 900 x 1200 mm / 0.57 m ³

INSTALLATION CLEARANCES (minimum)

Front	400 mm	Combustible Material Side	50 mm	Non-combustible Side	0 mm
Floor	150 mm	Combustible Material Rear	150 mm	Non-combustible Rear	50 mm

Please note, due to ongoing product development and improvement, we reserve the right to change product design and specification at any time without notice.



1800 013 123 | +61 2 9604 7333
sales@middleby.com.au
middleby.com.au

VIC - TAS - 47 Stubbs Street, Kensington VIC 3031
QLD - U12, 210 Queensport Rd Nth, Murarrie QLD 4172
WA - U2, 9 Meares Way, Canning Vale WA 6155, 08 9456 0559

HEAD OFFICE AND MANUFACTURING PLANT
211-217 Woodpark Road, Smithfield NSW 2164

v1_2022