



800 SERIES FRYER

2 baskets, split pan

VFGTL – Gas

- "V" pan fryer combines high energy efficiency, quick response and recovery and cooking flexibility
- +/- 2°C precision thermostat for optimum control
- Rapid heating response and continuous pilot ignition
- Stainless steel pan for easy cleaning
- Cover/joiner strips available for multi-unit installations
- Large cool zone for long oil life
- Line-up nosing

Other options

Night lid

Cover/joiner strips

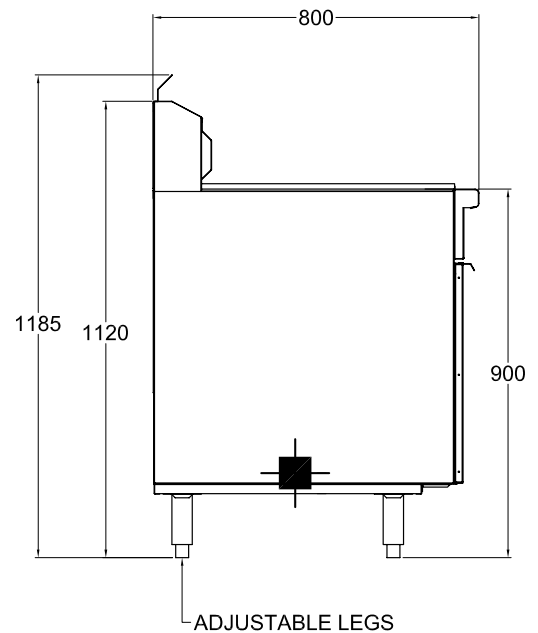
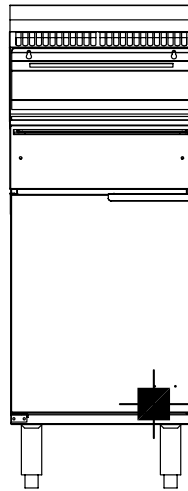
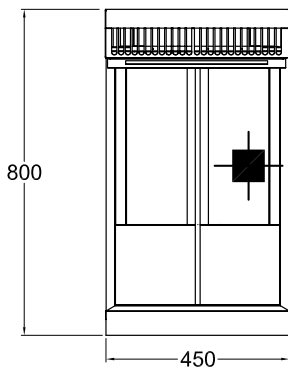

VFGTL 2 baskets, split pan

SPECIFICATION

Dimensions (WxDxH)	450 x 800 x 1120 mm
Working height	900 mm (±20 mm)
Pan Size (WxDxH)	176 x 353 x 300 mm (2 off)
Capacity	16 L per pan

■ 3/4" BSP Gas Connection

Gas Connection	3/4" BSP
Rating	105 MJ
Weight	80 kg
Packed	0.5 m ³

Australia's premier food service equipment manufacturer

middleby.com.au

211-217 Woodpark Road, Smithfield NSW 2164
1800 013 123 | +61 2 9604 7333

 **MIDDLEBY AUSTRALIA**

