

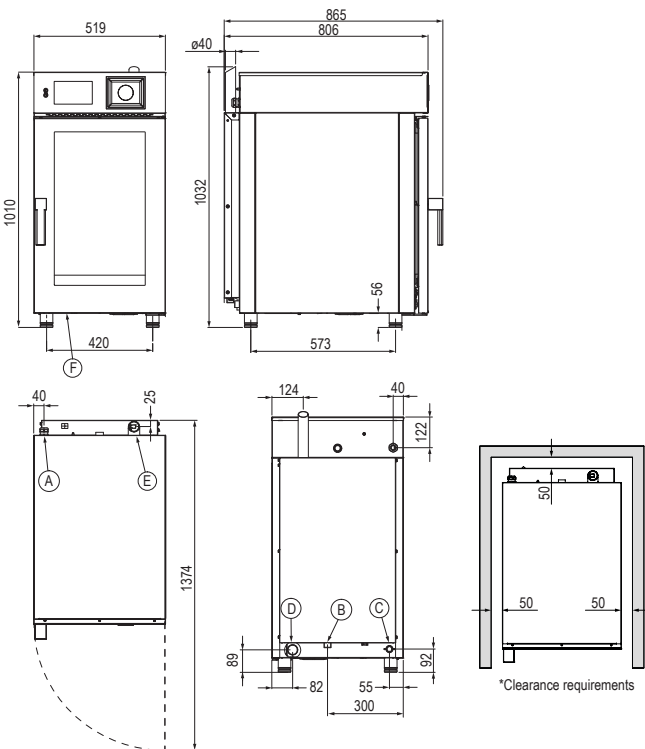

Product Information:

- Compact unit at only 519mm wide (30% less space required than traditional ovens)
- **Symbiotic Steam (patented)** innovative, heavy duty, highly efficient, dual boiler generation and steam injection oven
- **Steam Tuner (patented)** exclusive feature allows actual tuning of saturated steam
- **Meteo System (patented)** for precise control and saturation levels
- Automatic descaling system for oven and boiler
- Integrated recirculating cleaning via tablet, with liquid detergent dispenser installed if preferred
- Large 7" innovative touch screen interface
- Over 120 pre-set cooking programs, 1,000+ additional programs - 9 phase memory available
- Automatic, adaptive cooking, rack control, regeneration, sous vide and smoking programs
- Easy Service function, Recipe tuner, and Chef's note software all as standard
- 6-speed inverter controlled fan for increased precision, control and reliability
- LED lighting for superior cavity illumination
- USB connection, HACCP
- Supplied with multi-point core temperature probe, drain kit and advanced scale reduction filter
- Left hand hinge door option available
- All combi ovens are supplied with either Standard or Reverse Osmosis Filtration system
- 48-month warranty (Terms and conditions apply)

General Drawing:



Heat Source: 500mm clearance from an external heat source is required in order to protect the oven control components. For clearances under 500mm, it is mandatory for Stoddart heat shields to be fitted while still maintaining a minimum clearance of 50mm to allow access to the unit. Failure to adhere to minimum clearances may void the oven warranty or add service costs due to lack of access.

Non-Heat Source: 50mm clearance from a non-heat source to allow access to the unit.

Due to continuous product research and development, the information contained herein is subject to change without notice.

Revision: 05 - 02/09/2022 - A

www.stoddart.com.au

www.stoddart.co.nz

Specifications:

Model - Standard Filter	KB101WT.SF
Model - Reverse Osmosis	KB101WT.RO
W x D x H (mm)	519 x 865 x 1032
Weight	110kg
Capacity	10 x 1/1 GN Pans
Packed Dimensions (mm) / Weight	
Electrical Connection	3Ø + N + E 415VAC / 50Hz / 14.8kW
Cold Water Connection	3/4 BSP 150-350 kpa Min 10°C - Max 35°C
Water Quality Requirements	Hardness 60-100ppm TDS <100mg/L Cl Chloride <32mg/L

Legend:

- A** Electrical Connection
- B** Steam Generation Water Inlet 3/4" BSP
- C** Wash System Water Inlet 3/4" BSP
- D** Drain Connection 40mm
- E** Humidity Vent
- F** Detergent & Rinse Aid Inlet

