

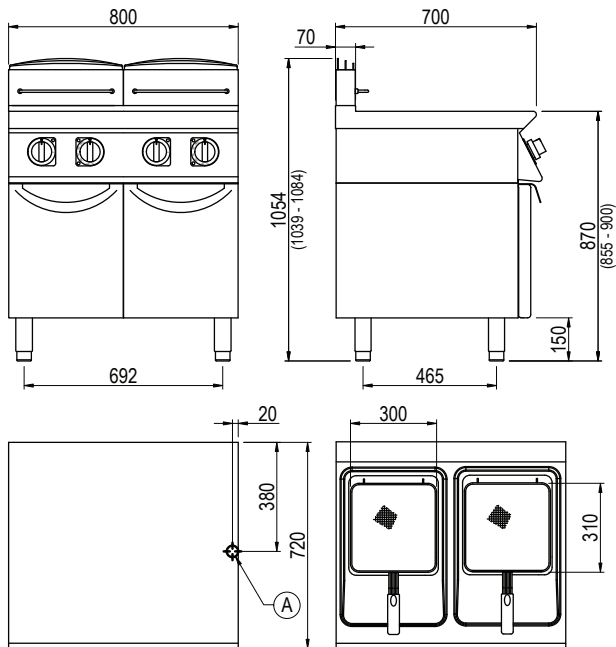

Product Information:

- Class leading, European style, professional quality and reliability since 1963
- 700 series, electric 2 x 17 litre, double pan fryer (35.6kW)
- Immersed heating elements with Hi-limit temperature protection and manual reset. Rotating mechanism to facilitate easy cleaning inside the tank.
- Temperature regulation via thermostat (100°C – 195°C)
- Thermostat bulbs protected against accidental impact
- Cold zone on the bottom of the tank to collect residues and prevent tainting of oil
- 2x 310x345mm single tanks with oil drainage via ball valve into integrated oil capture drawer
- Indicator lights to monitor the correct operation of the appliance
- Robust 304 grade stainless steel construction with rounded corners for improved cleaning
- Pressed top work surface with raised edges to protect from overflow
- Enclosed base with front access doors
- Height adjustable stainless steel feet for a 900mm working height
- Supplied with removable mesh basket support, 2x 300x310x120mm baskets and lids
- Additional baskets sold separately (see below)
- 24-month warranty

General Drawing:



Optional extra basket configuration:

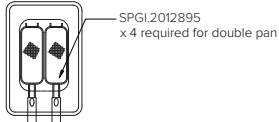

Due to continuous product research and development, the information contained herein is subject to change without notice.

Revision: 01 - 05/01/2022 - A

www.stoddart.com.au

www.stoddart.co.nz

Specifications:

Model	FE7217T
W x D x H (mm)	800 x 720 x 1054
Weight	90kg
Oil Capacity	2 x 17L
Packed Dimensions (mm)	845 x 825 x 1200
Packed Weight (mm)	80kg
Electrical Connection	3Ø + N + E 415VAC / 50Hz / 35.6kW

Legend:

A Electrical Connection

