



# ASIAN COOKING RANGES, WOKS

with side Burners

## CWA2B2 - Gas

- Air cooled decks for maximum water efficiency – saves 90% of water usage
- Fresh water swivel spout with tap
- Manually operated water control tap
- All stainless steel construction
- Heavy duty dual ringed burner
- Heavy duty duckbill burner

### Other options

Front or rear drain trough

Any combination of burners arrangement – Double ring, Mongolian or Duckbill burners



Units 9 & 10  
124-130 Auburn Street  
Wollongong

02 4226 9779  
info@kwikhe.com.au

kwikhe.com.au

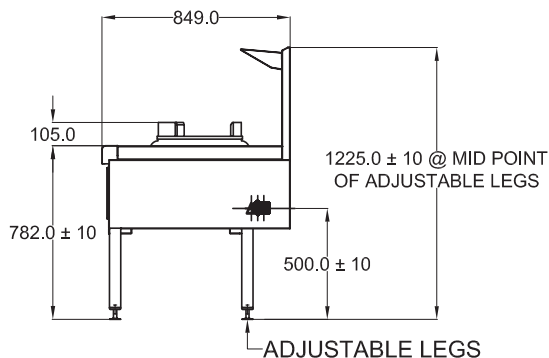
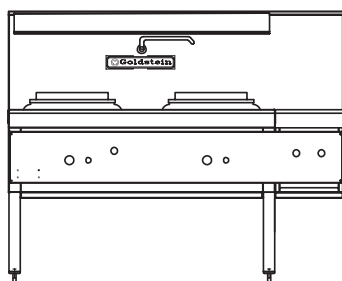
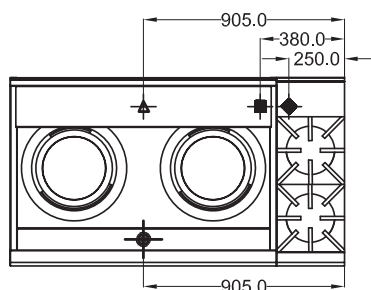

## CWA2B2 2 burners

### SPECIFICATIONS

<b>Dimensions (WxDxH)</b>	1505 x 850 x 1225 mm
<b>Working height</b>	900 mm
<b>Wok size (diameter)</b>	2x 356 mm
<b>Wok type</b>	Dual Ring / Mongolian / Duckbill

- ◆ 3/4" BSB Gas Inlet
- ▲ 1/2" BSP Water Inlet
- ✦ 1 1/2" Waste Drain

<b>Gas Connection</b>	3/4" BSP
<b>Rating</b>	Dual Ring 160 Mj Mongolian 232 Mj Duckbill 292 Mj
<b>Weight</b>	210 kg
<b>Packed</b>	1.7 m <sup>3</sup>

Australia's premier food service equipment manufacturer

[middleby.com.au](http://middleby.com.au)

211-217 Woodpark Road, Smithfield NSW 2164  
1800 013 123 | +61 2 9604 7333

