

COMPACT WORKBENCH FRIDGES

- One level of shelving plus floor
- Panasonic designed compressors
- Can be positioned against walls
- Stainless steel exterior & interior with gal metal back
- Digital temp. controls & read-out
- Fan assisted cooling
- Auto defrost
- Self evaporating drainage
- Touch close doors
- Internal constructed for easy cleaning
- Castors
- Ambient 32°C & 60% RH

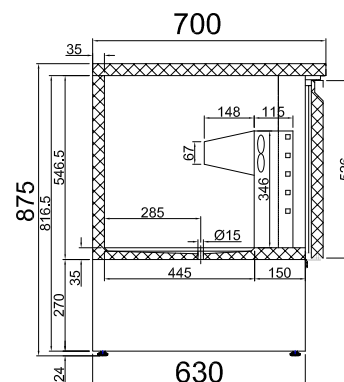
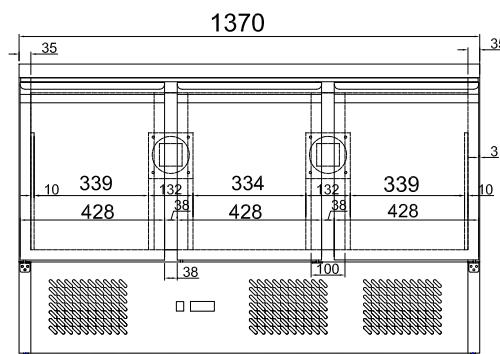
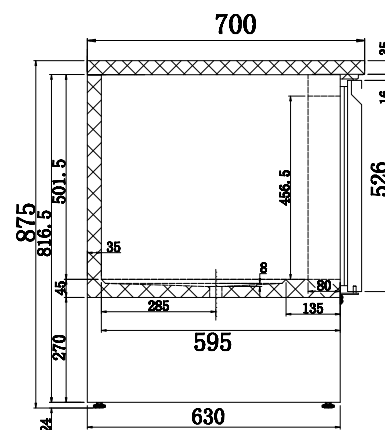
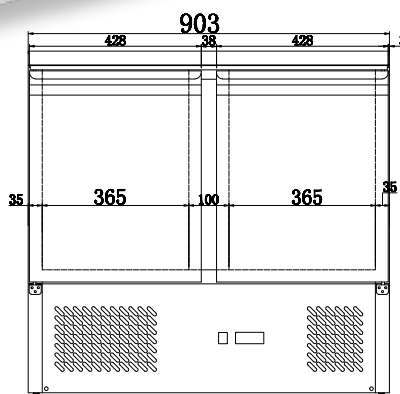

GNS900B

GNS1300B

Code	Litre	Dimensions (WxDxH mm)	Weight (kg)	Temperature Range °C	Ambient/ RH%	Voltage	Power (W/A)
2 Door							
GNS900B	257	903x700x892	72	-2 to +8	32/60	240	240/10
3 Door							
GNS1300B	400	1368x700x892	110	-2 to +8	32/60	240	240/10

Prices and specifications are subject to change without notice. Pictures are for illustrative purpose and final product may differ